

# Communication Interface Module Replacement

## Removal Procedure

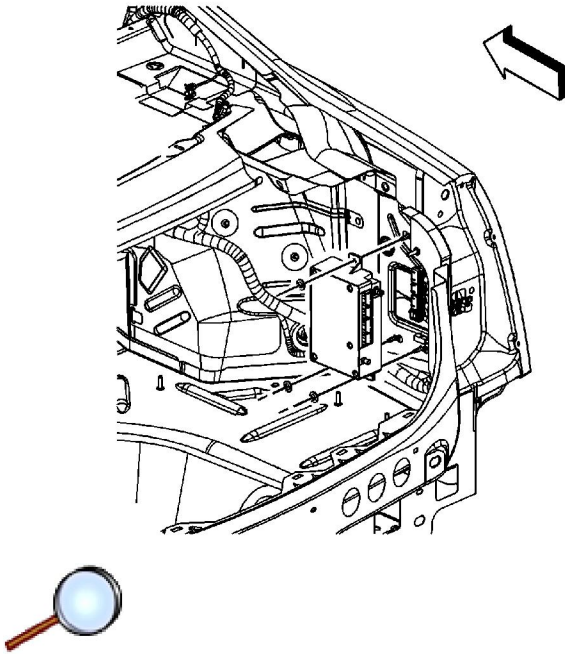

**Note:** The vehicle communication interface module (VCIM) has a specific set of unique numbers that tie the module to each vehicle. These numbers, the 10-digit station identification (STID) and the 11-digit electronic serial number (ESN), are used by the National Cellular Network and OnStar® to identify the specific vehicle. Because these numbers are tied to the vehicle identification number of the vehicle, you must never exchange these parts with those of another vehicle.

1. Remove the right rear compartment trim. Refer to [Rear Compartment Trim Panel Replacement](#).
2. Remove the nuts securing the OnStar® module to the vehicle body.

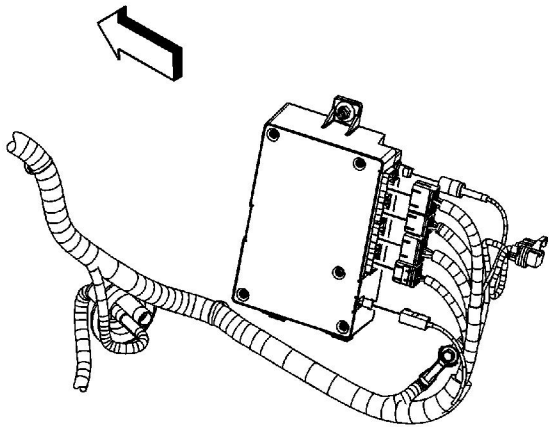

3. Disconnect all the electrical connectors from the module.
4. Remove the module from the vehicle.

### Installation Procedure

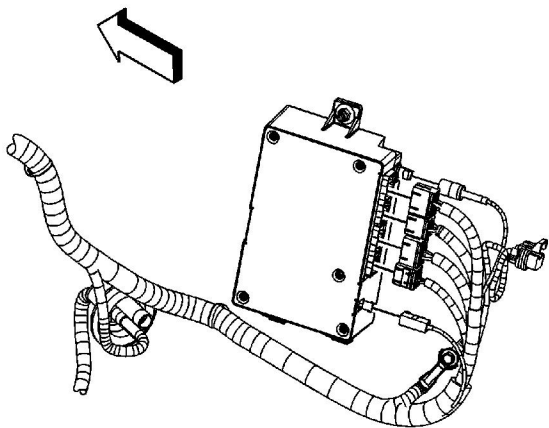

1. When replacing the VCIM, record the 11-digit ESN and the 10-digit STID number from the label on the new VCIM.
2. When replacing the VCIM, be sure to transfer the Bluetooth Antenna, if equipped.
3. Reconnect the electrical connectors the module.

**Caution:** Refer to [Fastener Caution](#) in the Preface section.

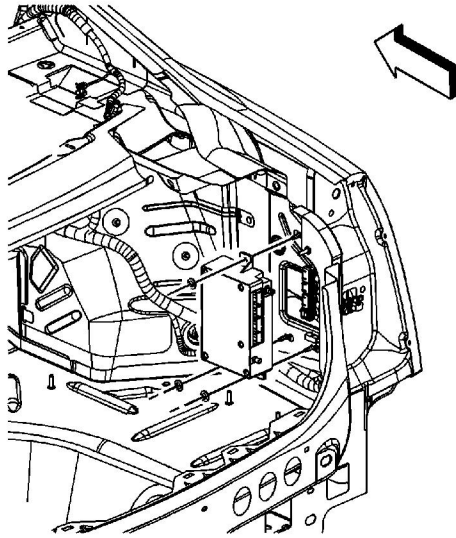

4. Install the module onto the vehicle and tighten the nuts to **9 N·m (80 lb in)**.

**Note:** After replacing the vehicle communication interface module, you must reconfigure the OnStar® system. Failure to reconfigure the system will result in an additional customer visit for repair. In addition, pressing and holding the white dot button on the keypad will NOT reset this version of the OnStar® system. This action will cause a DTC to set.

5. The default language for the new VCIM is English. Refer to the Module Setup screen if the customer requests French or Spanish Voice Recognition.
6. Refer to [Control Module References](#) for programming and set up information.